



**NATIONAL UNIVERSITY OF LESOTHO  
INSTITUTE OF EXTRA MURAL STUDIES  
RESEARCH, EVALUATION & MEDIA DEPARTMENT  
DIPLOMA IN MASS COMMUNICATION  
2022/2023 ACADEMIC YEAR**

**MAC 0106 – Photojournalism – Year 1  
First Semester Final Examination Paper**

.....  
**January 2023**

**Marks: 100**

**Time: 3 hrs.**  
.....

**Instructions:**

- Read all questions carefully before you answer.
- This paper has two sections.
- **In Section A is multiple choice questions that comprise 20 marks.**
- **In Section B, answer the eight (8) questions.**
- Number your answers exactly the same way they appear on the question paper.
- Please ensure that you proof-read all your answers.
- Marks will be deducted for untidy and/or illegible handwriting and grammar mistakes.
- Each question must be answered on a separate page.

## SECTION A – Multiple choice questions.

### Question 1 (20 Marks)

Circle the correct answer.

1. Photography is writing with light.  
A. True  
B. False
2. A lens is part of the camera where an artist set an f/number to get a good exposure.  
A. True  
B. False
3. A fast shutter speed can be used to freeze movement in an image.  
A. True  
B. False
4. A blurry image is the result of camera shake and poor combination of aperture + shutter speed  
A. True  
B. False
5. You can always mount camera on a tripod, when taking pictures.  
A. True  
B. False
6. A photojournalist can take and use the photograph in a newspaper without the permission of the person being photographed.  
A. True  
B. False
7. Description of a photo in a newspaper is called a caption.  
A. True  
B. False
8. A Rule of thirds, rule of odds and rule of space are techniques of composition.  
A. True  
B. False
9. The negative space in a picture gives a good picture.  
A. True  
B. False
10. A film and light sensor both do the same work in a camera.  
A. True  
B. False
11. You can make good story telling compositions with a single lens reflex camera.  
A. True  
B. False
12. A single lens reflex camera has a focal plane shutter.  
A. True  
B. False

13. The aperture also controls the depth-of-field.
  - A. True
  - B. False
  
14. An aperture is an opening in lens to allow light into the camera.
  - A. True
  - B. False
  
15. Ethics are applied in photojournalism.
  - A. True
  - B. False
  
16. A photojournalist going out to the field has to carry different types of lenses
  - A. True
  - B. False
  
17. Photographic portfolio is a collection of important photos a photographer wants to display for specific purposes.
  - A. True
  - B. False
  
18. Defining Your Purpose and Goal, Gathering the Content and Putting It All Together, are points to consider when building your portfolio as a photojournalist.
  - A. True
  - B. False
  
19. Captions and cut lines describe a photo in photojournalism.
  - A. True
  - B. False
  
20. Photo manipulation has been regularly used to deceive or persuade viewers, or for improved
  - A. True
  - B. False

[20]

**SECTION B – Answer all questions.**

**Question 2**

Define a camera, and where the word camera comes from. Give five (5) types of cameras you know. **[20]**

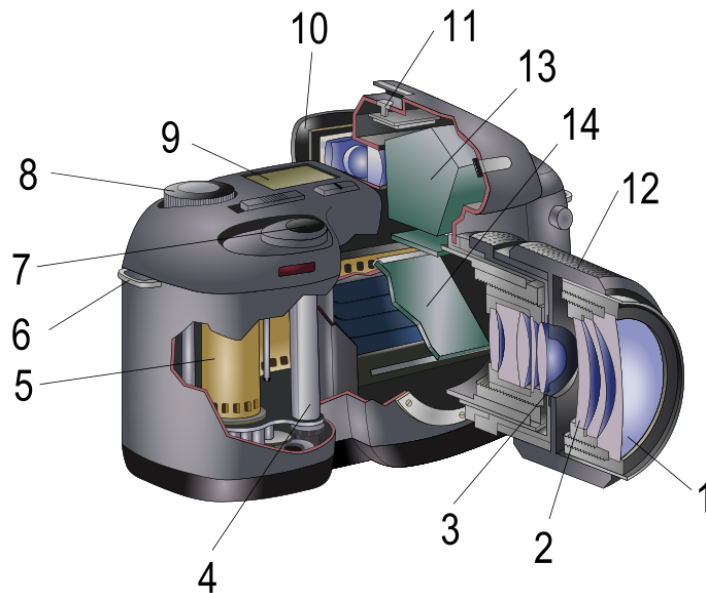

This is a numbered cross section of a film camera. Name the 1 to 10 numbered parts. **[10]**

**Question 3**

The language of photography is distinguished from other visual arts by its two (2) essential elements, which are light and camera. Do you agree with the statement? Explain the two (2) essential elements: light and camera. **[10]**

**Question 4**

Define photojournalism and give its three (3) qualities of it. **[10]**

Question 5

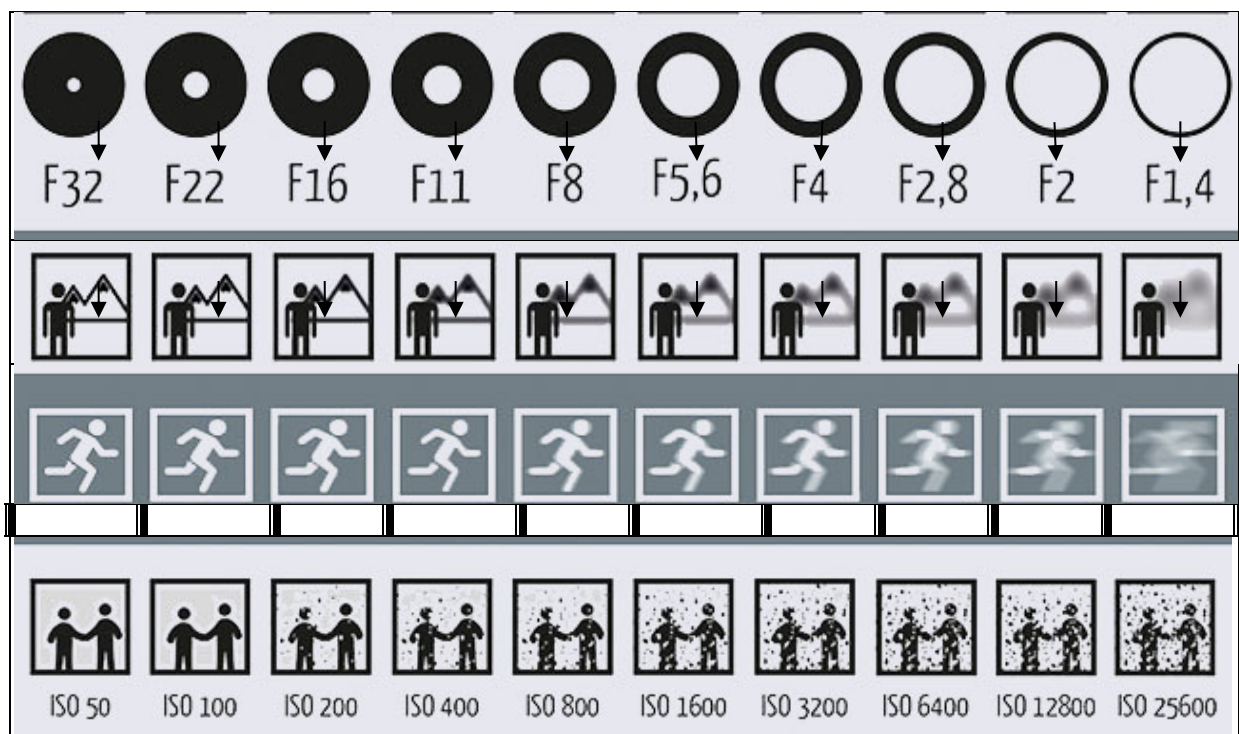

The diagram shows the relationship of: aperture, shutter and ISO. In the blank spaces, give the corresponding shutter speed settings from these: 1/2; 1/125; 1/30; 1/250; 1/1000; 1/15; 1/4; 1/500; 1/8; and 1/60. [10]

Question 6

Define composition in photography, and give examples. [10]

Question 7

Fill in missing words from the list: effect, unacceptable, subject, distance, farthest, adequate, sharp, subjective, matter, trying. **[10]**

Depth of field is the amount of ..... between the nearest and ..... objects that appear in acceptably .....focus in a photograph. A preferred selection Depth of Field (DOF) in a focused subject in a.....in an image can be quite ..... Remember this.....selection of DOF for one situation; application may be ..... for another photographer. It is all a..... of personal preference when .....to determine the appropriate use of DOF to enhance an.....in a photograph. [10]

**Question 8**

Describe a pinhole camera, and whether it is possible to take an image with it. How will the image appear? Why does it work?

**[10]**

**Question 9**

What is meant by photo essays? Give an example.

**[10]**